

OUR COMPETENCE, YOUR INNOVATION.

bauma CHINA, Shanghai, SNIIEC
November 24-27, 2026



International Trade Fair for Construction Machinery,
Building Material Machines, Mining Machines and
Construction Vehicles.

www.bauma-china.com

bauma CHINA

Contents

1. Integrated Package

- 1.1 Premium Package 1 02
- 1.2 Premium Package 2 02





2. Online Package

- 2.1 Online Package 1 03
- 2.2 Online Package 2 03
- 2.3 Online Package 3 03



3. Great Value Package

- 3.1 Pre-registration Package 04
- 3.2 WeChat Mini Program Package 04
- 3.3 Multi-channel Logo Package 05
- 3.4 Recommended Exhibitors Package 05

4. Digital Promotion

- 4.1 WeChat Official Account 06
- 4.2 WeChat Mini Program **NEW** 07
- 4.3 Co-branded e-Poster on WeChat  08
- 4.4 WeChat/Mini Program Registration Page  08
- 4.5 WeChat/Mini Program E-badge  09
- 4.6 Web Registration Page  09
- 4.7 Pre-registration Confirmation Letter 10
- 4.8 Official Show Website Banner 10
- 4.9 bauma CHINA Community (Exhibitor Directory)  11

5. On-site Promotion

- 5.1 Visitor Guide  12
- 5.2 Show Map **Excl.** 13
- 5.3 Visitor Lanyard **Excl.** 13
- 5.4 Show Badge **Excl.** 14
- 5.5 Show Bag  14
- 5.6 Official Waterproof Windbreaker **Excl.** 15

6. SNIEC Venue Advertising

- 6.1 Movable Signage 16
- 6.2 Four-sides Signage **NEW** 16
- 6.3 Corridor Hanging Banner 17
- 6.4 Entrance Hall Hanging Screen 17
- 6.5 Corridor Banner in South Entrance Hall 18
- 6.6 Movable Ad. Board in North Entrance Hall 18
- 6.7 LED Screen Ad. in Entrance Halls 19
- 6.8 Glass Facade Outside the Entrance Hall  19
- 6.9 Connecting Galleria Glass Facade **NEW** 20
- 6.10 Corridor Billboard 20
- 6.11 Corridor Post 21
- 6.12 Visitor Registration Signage 21
- 6.13 Floor Marks 22
- 6.14 Rest Area 22
- 6.15 Toilets Ad. 23
- 6.16 Hall Floorplan Guide 23
- 6.17 Self-service Badge Printer **NEW** 24

7. Ad. around the SNIEC

- 7.1 Outside Corridor Ad. at the North Square **Excl.** 25
- 7.2 Entrance Square Billboard 25
- 7.3 Outside Wall Sticker Ad. at the North Square 26
- 7.4 Perforated Window Ad. (Hall Exterior)  26
- 7.5 Ad. in VIP Parking Lot **NEW** 27
- 7.6 Ad. in Front of the Gate at the South Square 27

8. Location Map of On-site Ad. 28

Bauma CHINA 2026



You may wonder how to maximize your show effect on the largest construction machinery show in Asia!

- How to distinguish your company from the masses and get the attention of 280,000⁺ visitors?
- How to stand out from 3,500⁺ exhibitors?
- How to attract your target customers swarming into your booth?

Boost your business with our services!

bauma CHINA 2026 offers good ideas for your exhibition promotion strategy from the online promotion to onsite advertising.

Pre-show	1. Integrated Package
	2. Online Package
	3. Great value Package
	4. Digital Promotion
During the Show	1. Integrated Package
	2. Online Package
	3.2 WeChat Mini Program Package
	3.3 Multi-channel Logo Package
	3.4 Recommended Exhibitors Package
	4.1 WeChat Official Account
	4.2 WeChat Mini Program
	4.4 WeChat/Mini Program Registration Page
	4.5 WeChat/Mini Program E-badge
	4.6 Web Registration Page
	4.8 Official Show Website Banner
	4.9 bauma CHINA Community (Exhibitor Directory)
	5. On-site Promotion
6. SNIEC Venue Advertising	
7. Ad. around the SNIEC	
After Show	3.4 Recommended Exhibitors Package
	4.1 WeChat Official Account
	4.2 WeChat Mini Program
	4.8 Official Show Website Banner
	4.9 bauma CHINA Community (Exhibitor Directory)

1. Integrated Package

1. Integrated Package

1.1 Premium Package 1

Pre-show During the Show

★ ★ ★
Recommendation

- **5**× Corridor hanging banner
- **1**× Entrance square billboard
- **1**× WeChat co-branded e-poster
- **2**× WeChat non-headline articles
- **1** Month top banner on WeChat Mini Program homepage
- **1**× Logo on the floorplan in Visitor Guide only

* Ad. design provided by sponsor.
Issue dates subject to organizer's marketing plan and mutual agreement.
("WeChat Mini Program Homepage Top Banner" timing selectable between July-Oct.)

Booking deadline: Sep. 9, 2026

Price: RMB 188,000

2. Online Package

3. Great Value Package

4. Digital Promotion

5. On-site Promotion

6. SNIEC Venue Advertising

7. Ad. around the SNIEC

1.2 Premium Package 2

Pre-show During the Show

★ ★ ★
Recommendation

- **1**× Entrance square billboard
- **1**× Corridor billboard
- **2**× WeChat non-headline articles
- **1**× Logo on the floorplan in Visitor Guide only

* Ad. design provided by sponsor.
Issue dates subject to organizer's marketing plan and mutual agreement.
("Corridor Billboard" in this package doesn't include the location of entrance to halls.)

Booking deadline: Sep. 9, 2026

Price: RMB 108,000

2. Online Package

	<div style="background-color: #FFD700; padding: 2px;">Pre-show</div> <div style="background-color: #0056B3; color: white; padding: 2px;">During the Show</div>	 Recommendation	 Recommendation	 Recommendation
Sponsorship		2.1 Online Package 1	2.2 Online Package 2	2.3 Online Package 3
1×Month top banner on WeChat Mini Program homepage		✓		
1×Month stage banner on show website homepage		✓		
1×Banner on Web Registration Page			✓	
1×Month banner on all inner pages of show website				✓
1×Co-branded e-poster on official WeChat		✓		
1×WeChat non-headline articles		✓	✓	
1×Banner in WeChat headline article			✓	✓
Banner in Official E-newsletter		1 issue	2 issues	1 issue
Price		RMB 90,000	RMB 52,000	RMB 25,000

* Ad. design provided by sponsor.

Issue dates subject to organizer's marketing plan and mutual agreement.

("Stage banner on the homepage of official website" "Banner on Pre-registration page" "Banner on all official website inner pages" timing selectable between July-Oct.)

Booking deadline: Sep. 9, 2026

1. Integrated Package

2. Online Package

3. Great Value Package

4. Digital Promotion

5. On-site Promotion

6. SNIEC Venue Advertising

7. Ad. around the SNIEC

3. Great Value Package

3.1 Pre-registration Package

Pre-show

★★★★ Recommendation

- o 1 Month banner on WeChat/Mini Program registration page
- o 1 Month banner on WeChat/Mini Program e-badge
- o 1 Month banner on pre-registration page
- o 1 Month banner on registration confirmation letter



* Ad. design provided by sponsor.

Booking deadline:
2 weeks before launching

Price: RMB 150,000, 1 month in Nov.
RMB 80,000, 1 month in July.-Oct.

3.2 WeChat Mini Program Package

Pre-show During the Show

★★★★ Recommendation

- o 1 Month splash screen Ad. on WeChat Mini Program
- o 17x Floor marks
- o Quantity: 1 issue



* Ad. design provided by sponsor.

Booking deadline: Sep. 9, 2026

Price: RMB 150,000

1. Integrated Package

2. Online Package

3. Great Value Package

4. Digital Promotion

5. On-site Promotion

6. SNEEC Venue Advertising

7. Ad. around the SNEEC

3. Great Value Package

3.3 Multi-channel Logo Package

Pre-show During the Show

★★★★ Recommendation

- o Logo on onsite billboard floorplan
- o Logo on show website floorplan
- o Logo on WeChat Mini Program floorplan
- o Logo on printed Visitor Guide floorplan

o Quantity: 1 issue

* Ad. design provided by sponsor.



Booking deadline: Sep. 9, 2026

Price: RMB 60,000

3.4 Recommended Exhibitors Package

Pre-show During the Show After the show

★★★★ Recommendation

- o Exhibitor Recommendation on bauma CHINA Community and WeChat Mini Program

o Quantity: 1 year

* Ad. design provided by sponsor.



Booking deadline: 2 weeks before launching

Price: RMB 60,000

1. Integrated Package

2. Online Package

3. Great Value Package

4. Digital Promotion

5. On-site Promotion

6. SNEEC Venue Advertising

7. Ad. around the SNEEC

4. Digital Promotion

4.1 WeChat Official Account

Pre-show During the Show
After the show

★★★★
Recommendation

- With **220,000+** followers, bauma CHINA WeChat is an unmissable platform for you to share latest products/services and other information of your company.
- Articles can reach up to **45,000** readers per issue.
- **Form 1:** Banner in headline article | JPG/PNG
- Size: Bottom banner: 1080px (W) × 560px (H)
- **Form 2:** Non-headline WeChat article
- Format: Article
- **Form 3:** Combined banner and article package
- Format: Article + pictures
- Quantity: 1 issue
- Ad. design provided by sponsor.
- * Issue dates subject to organizer's marketing plan and mutual agreement.



Booking deadline:
2 weeks before sending

Price: RMB 12,000, Form 1
RMB 18,000, Form 2
RMB 28,000, Form 3

1. Integrated Package

2. Online Package

3. Great Value Package

4. Digital Promotion

5. On-site Promotion

6. SNEEC Venue Advertising

7. Ad. around the SNEEC

4. Digital Promotion

NEW 4.2 WeChat Mini Program

Pre-show During the Show
After the show

★ ★ ★
Recommendation

- Essential digital "Visitor Guide" for show planning & onsite navigation.
- Reaches **100,000+** active visitors with over **3 million** impressions.
- High revisit frequency ensures strong brand recall.

- **Form 1:** Splash Screen Ad. 
- Size: 600px (W) × 840px (H), ≤500KB
- **Form 2:** Homepage Top Banner (Rotating)
- Size: 1000px (W) × 836px (H), ≤500KB
- **Form 3:** Exhibitor Directory Banner (List Pages Only)
- Size: 500px (W) × 122px (H), ≤300KB
- Quantity: 1 issue

* Ad. design provided by sponsor.



Booking deadline:
2 weeks before launching

Price: RMB 68,000, Form 1, 1 month in July.-Oct.
RMB 100,000, Form 1, 1 month in Nov.
RMB 38,000, Form 2, 1 month in July.-Oct.
RMB 50,000, Form 2, 1 month in Nov.
RMB 38,000, Form 3, 1 month in July.-Oct.
RMB 50,000, Form 3, 1 month in Nov.

1. Integrated Package

2. Online Package

3. Great Value Package

4. Digital Promotion

5. On-site Promotion

6. SNEEC Venue Advertising

7. Ad. around the SNEEC

4. Digital Promotion

4.3 Co-branded e-Poster on WeChat



4.3 Co-branded e-Poster on WeChat

- o Headline placement on official WeChat reaching over **220,000** followers.
- o Highly popular and shareable promotion format.
- o Form: Headline Post | JPG/PNG
- o Quantity: 1 issue
- * Image is provided by the sponsor and the final Ad. will be designed by the organizer.
Issue dates subject to organizer's marketing plan and mutual agreement.

Pre-show

★★★★
Recommendation



Booking deadline: 2 weeks before sending

Price: RMB 38,000

1. Integrated Package

2. Online Package

3. Great Value Package

4. Digital Promotion

5. On-site Promotion

6. SNEEC Venue Advertising

7. Ad. around the SNEEC



4.4 WeChat/Mini Program Registration Page

- o **68% of domestic visitors** choose to pre-register via the official WeChat platform.
- o **99% of on-site registrations** occur via mobile devices.
- o Prolonged User Exposure During Sign-up Process
- o Form: JPG/PNG
- o Size: 750px (W) × 180px (H), 300 dpi
- o Quantity: 1 month in July.-Oct.
1 month in Nov.
- * Ad. design provided by sponsor.

Pre-show During the Show

★★★★
Recommendation



Booking deadline:
2 weeks before launching

Price: RMB 38,000, 1 month in July.-Oct.
RMB 58,000, 1 month in Nov.

4. Digital Promotion



4.5 WeChat/Mini Program E-badge

Pre-show During the Show

★★★
Recommendation

- o **68% of domestic visitors** register via official WeChat platform and get E-badges which will be shown on site for check-in.
- o **99% of on-site registrations** occur via mobile devices.
- o An effective and targeted exhibition pre-promotion method.

- o Form: JPG/PNG
- o Size: 750px (W) × 180px (H), 300 dpi
- o Quantity: 1 month in July.-Oct.
1 month in Nov.

* Ad. design provided by sponsor.
Different pricing applies for November due to peak registration period.



Booking deadline:
2 weeks before launching

Price: RMB 38,000, 1 month in July.-Oct.
RMB 58,000, 1 month in Nov.



4.6 Web Registration Page

Pre-show During the Show

★★★
Recommendation

- o The must-read page for trade visitors has an average browsing time of **3 minutes per person**.
- o **80% of overseas visitors** register via website.
- o Great exposure to all the pre-registered visitors with maximum page view over **110,000** page views monthly.
- o Banner links directly to your company website.

- o Form: JPG/PNG
- o Size: 700px (W) × 100px (H), 150 dpi
- o Quantity: 1 month in July.-Oct.
1 month in Nov.

* Ad. design provided by sponsor.



Booking deadline:
2 weeks before launching

Price: RMB 25,000, 1 month in July.-Oct.
RMB 40,000, 1 month in Nov.

1. Integrated Package

2. Online Package

3. Great Value Package

4. Digital Promotion

5. On-site Promotion

6. SNEEC Venue Advertising

7. Ad. around the SNEEC

4. Digital Promotion

4.7 Pre-registration Confirmation Letter

Pre-show



Recommendation

- Feature your banner on the registration confirmation letter which will be printed by **all pre-registrants** and brought to the show.
- Significantly drive the traffic to your booth.
- Form: JPG/PNG
- Size: 700px (W) × 100px (H), 150 dpi
- Quantity: 1 month in July.-Oct.
1 month in Nov.



* Ad. design provided by sponsor.

Booking deadline:
2 weeks before sending

Price: RMB 25,000, 1 month in July.-Oct.
RMB 40,000, 1 month in Nov.

4.8 Official Show Website Banner

Pre-show

During the Show

After the show



Recommendation

- Banner on official website with good visits during the whole show period.
- Pageviews reach over **320,000** times/month at the peak time.
- Banner links directly to your company website.
- **Form 1:** Stage banner on homepage
- Size : 480px (W) × 276px (H), 150dpi
- **Form 2:** Banner on all inner pages
- Size : Top banner: 1334px (W) × 120px (H), 150dpi
Bottom banner: 920px (W) × 240px (H), 150dpi
- Quantity: 1 month in July.-Oct.
1 month in Nov.



* Ad. design provided by sponsor.

Booking deadline:
2 weeks before launching

Price: RMB 20,000, Form 1, 1 month in July.-Oct.
RMB 38,000, Form 1, 1 month in Nov.
RMB 20,000, Form 2, 1 month in July.-Oct.
RMB 30,000, Form 2, 1 month in Nov.

4. Digital Promotion

4.9 bauma CHINA Community (Exhibitor Directory)

Pre-show During the Show After the show

★ ★ ★ Recommendation

- o The community platform acts as a comprehensive exhibitor e-directory, providing you with the convenience of selecting exhibitors, products, and accompanying programs to effortlessly plan your visit.
- o It is also the virtual place where exhibitors reach out to potential clients at any time and where offline and online visitors to stay updated on the exhibitors' latest products and technologies as well as establish new business contacts. Featuring a live chat and online business matching, bauma CHINA Community furthermore is the ideal platform for exhibitors and visitors from all over the world to interact—before, during and after bauma CHINA.

- o **Form 1:** Web Homepage - Stage Banner
- o Size : PC: 1920px (W) × 550px (H), 72 dpi
Web: 1600px (W) × 750px (H), 72 dpi

- o **Form 2:** Web Homepage – Middle Banner
- o Size : PC: 1920px (W) × 320px (H), 72 dpi
Web: 760px (W) × 170px (H), 72 dpi

- o **Form 3:** Web Homepage – Exhibitor Recommendation
- o Size : the card and logo can directly link to your company website

- o **Form 4:** Web Company/Product List – Top Banner
- o Size : PC: 1920px (W) × 350px (H), 72 dpi
Web: 768px (W) × 300px (H), 72 dpi

- o **Form 5:** Web Company/Product List – Side Banner
- o Size : PC: 200px (W) × 260px (H), 72 dpi

* Ad. design provided by sponsor.



Booking deadline:
2 weeks before launching

Price: RMB 38,000, Form 1
RMB 28,000, Form 2
RMB 18,000, Form 3
RMB 28,000, Form 4
RMB 21,800, Form 5

1. Integrated Package

2. Online Package

3. Great Value Package

4. Digital Promotion

5. On-site Promotion

6. SNEEC Venue Advertising

7. Ad. around the SNEEC

5. On-site Promotion



5.1 Visitor Guide

During the Show

★ ★ ★
Recommendation

- Ad. in the Visitor Guide, the most useful printing material, delivered to about **280,000+** trade visitors
- A remarkable advertising opportunity to increase your visibility as well as an invaluable tool for directing traffic to your booth.



Excl.

- **Form 1:** Cover Pull-out Ad.
○ Size : 420mm(W) × 280mm(H) (+3mm bleed)

Excl.

- **Form 2:** Back Cover Ad.
○ Size : 210mm(W) × 280mm(H) (+3mm bleed)

- **Form 3:** Inside Front Cover, Inside Back Cover, Opening page Ad.
○ Size : 210mm(W) × 280mm(H) (+3mm bleed)

- **Form 4:** One page colour Ad.
○ Size : 210mm(W) × 280mm(H) (+3mm bleed)

- **Form 5:** Half page colour Ad.
○ Size : 210mm(W) × 140mm(H) (+3mm bleed)

- **Form 6:** Logo on the fairgrounds map
○ Logo : A 300dpi image file or PSD/AI file

○ Quantity: 100,000 copies

* Multiple purchases of this sponsorship item are allowed. Ad. design or Logo is provided by the sponsor. Visitor Guide are made by the organizer.



Booking deadline:
Oct. 10, 2026

Price: RMB 140,000, Form 1
RMB 120,000, Form 2
RMB 80,000, Form 3
RMB 40,000, Form 4
RMB 25,000, Form 5
RMB 15,000, Form 6

1. Integrated Package

2. Online Package

3. Great Value Package

4. Digital Promotion

5. On-site Promotion

6. SNIEC Venue Advertising

7. Ad. around the SNIEC

5. On-site Promotion

Excl. 5.2 Show Map

- The show map carried by the all visitors presents the layout of the entire exhibition hall, offering premium, unavoidable brand exposure.
 - Form: Back Cover Ad.
 - Size: 210mm(W) × 290mm(H) (+3mm bleed)
 - Quantity: 150,000 copies
- * Ad. Design is provided by the sponsor. Show map are made by the organizer.

During the Show

★★★
Recommendation



Booking deadline: Oct. 10, 2026

Price: RMB 100,000

Excl. 5.3 Visitor Lanyard

- Turns attendees into walking advertisements, delivering continuous brand visibility from entrance to exit, every day of the show.
 - Quantity: 150,000 pieces
- * Ad. design is provided by the exhibitor and must be approved by the organizer. Visitor Lanyards are made by the organizer.

During the Show

★★
Recommendation



Booking deadline: Sep. 9, 2026

Price: RMB 350,000

1. Integrated Package

2. Online Package

3. Great Value Package

4. Digital Promotion

5. On-site Promotion

6. SNEC Venue Advertising

7. Ad. around the SNEC

5. On-site Promotion

Excl. 5.4 Show Badge

- Secure exclusive branding on every visitor badge. Your logo, name, and booth number gain continuous exposure to all attendees—effectively building brand awareness and directing traffic to your space.
- Size: 100(W)mm(W) × 35mm(H) (+3mm bleed)
- Quantity: 150,000 pieces
- * Ad. design is provided by the exhibitor and must be approved by the organizer.
Show Badges are made by the organizer.

During the Show

★★
Recommendation



Booking deadline: Sep. 9, 2026

Price: RMB 250,000



5.5 Show Bag

- Mobile advertising carrying your logo & booth info distributed to all visitors.
- Extended visibility with post-show reuse ensuring lasting promotion.
- Quantity: 50,000 pieces
- * Ad. design and production are provided by the sponsor and must be approved by the organizer.
bauma CHINA logo must be printed on Show Bags.

During the Show

★★★
Recommendation



Booking deadline: Aug. 9, 2026

Price: RMB 150,000 and show bags

1. Integrated Package

2. Online Package

3. Great Value Package

4. Digital Promotion

5. On-site Promotion

6. SNEEC Venue Advertising

7. Ad. around the SNEEC

5. On-site Promotion

Excl. 5.6 Official Waterproof Windbreaker

- Your logo will be printed on the official waterproof windbreaker which is the designated uniform for onsite staff.
- Quantity: 200 pieces
- * Clothings purchases and logo print are afforded by the sponsor and must be approved by the organizer. bauma CHINA logo must be printed on clothings.

During the Show

★
Recommendation



Booking deadline: Aug. 9, 2026

Price: RMB 100,000

1. Integrated Package

2. Online Package

3. Great Value Package

4. Digital Promotion

5. On-site Promotion

6. SNIIEC Venue Advertising

7. Ad. around the SNIIEC

6. SNIIEC Venue Advertising

1. Integrated Package

2. Online Package

3. Great Value Package

4. Digital Promotion

5. On-site Promotion

6. SNIIEC Venue Advertising

7. Ad. around the SNIIEC

6.1 Movable Signage

During the Show

★★★
Recommendation

- Company's key vision and booth number on the signpost that will be placed at high-visibility outdoor locations.
 - Location: clearly visible position at the square out of the exhibition hall
 - Size: 5m (W) × 4m (H) / 1 side
4m (W) × 5m (H) / 3 sides
 - Quantity: 1 side/set
3 sides/set
- * Ad. design is provided by the sponsor and must be approved by the organizer.
Moveable signposts are made by the organizer.

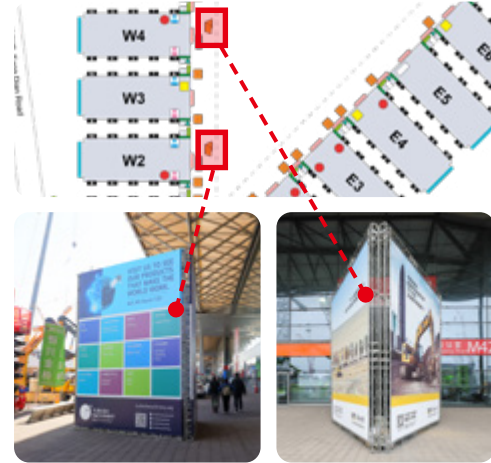

Booking deadline: Sep. 9, 2026

Price: RMB 40,000, 1 side
RMB 100,000, 3 sides

NEW

6.2 Four sides Signpost

During the Show

★★★
Recommendation

- clearly visible position at the square out of the exhibition hall (except Hall W4/E6)
 - Location: clearly visible position at the square out of the hall (except Hall W4/E6)
 - Size: 3m (W) × 4m (H)
 - Quantity: 4 sides/set
- * Ad. design is provided by the sponsor and must be approved by the organizer.
Banners are made by the organizer.



Booking deadline: Sep. 9, 2026

Price: RMB 120,000, 4 sides/set

6. SNIIEC Venue Advertising

1. Integrated Package

2. Online Package

3. Great Value Package

4. Digital Promotion

5. On-site Promotion

6. SNIIEC Venue Advertising

7. Ad. around the SNIIEC

6.3 Corridor Hanging Banner

During the Show

★★
Recommendation

- Suspended advertisements lead visitors to your booth.
 - Catch visitors' attentions by intensive double-sided advertisements.
 - **Location1:** #1 South Entrance to Hall E1
#3 East Entrance to Hall E7
 - Size: 3.5m (W) × 0.7m (H)
 - Quantity: 10 pieces/set
 - **Location2:** Hall N1 to N5 (except N2 to N3)
 - Size: 5m (W) × 0.7m (H)
 - Quantity: 10 pieces/set
 - **Location3:** Hall W1 to W5 / Hall E1 to E7
 - Size: 5m (W) × 0.7m (H)
 - Quantity: 10 pieces/set (9 pieces/set between W4-5)
- * Ad. design is provided by the sponsor and must be approved by the organizer.
Banners are made by the organizer.



Booking deadline: Sep. 9, 2026

Price: RMB 100,000, 10 pieces/set

6.4 Entrance Hall Hanging Screen

During the Show

★★★
Recommendation

- Dominating entrance hall placements capture 100% attendee exposure.
 - **Location 1:** #1 South Entrance Hall
 - Size: 15m (W) × 3.8m (H)
 - Quantity: 1 piece/image
- * Ad. design is provided by the sponsor and must be approved by the organizer.
Banners are made by the organizer.

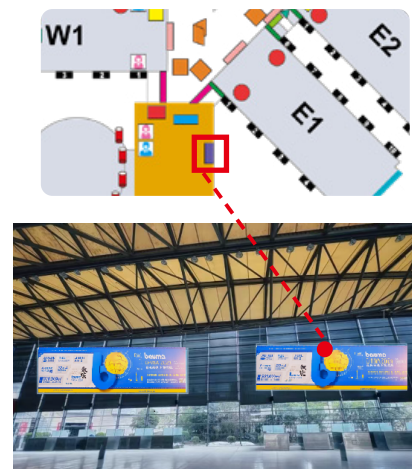

Booking deadline:
Sep. 9, 2026

Price: RMB 158,000, 1# South Entrance Hall/1 piece

6. SNIEC Venue Advertising

1. Integrated Package

2. Online Package

3. Great Value Package

4. Digital Promotion

5. On-site Promotion

6. SNIEC Venue Advertising

7. Ad. around the SNIEC

6.5 Corridor Banner in South Entrance Hall

During the Show

★★★
Recommendation

o The Ad. on the golden position of the south entrance hall and only 2 pieces of Ad. are available

- o Location: #1 South Entrance Hall
- o Size: 4m (W) × 5m (H)
- o Quantity: 1 piece
2 pieces/set

* Ad. design is provided by the sponsor and must be approved by the organizer.
Banners are made by the organizer.

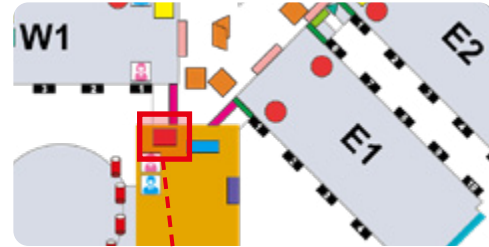

Booking deadline: Sep. 9, 2026

Price: RMB 60,000, 1 piece
RMB 100,000, 2 pieces/set

6.6 Movable Ad. Board in North Entrance Hall

During the Show

★★★
Recommendation

o The North Entrance Hall is nearby the metro and your Ad. will have an excellent exposure

- o Location: #2 North Entrance Hall
- o Size: 4m (W) × 3m (H)
- o Quantity: 1 piece

* Ad. design is provided by the sponsor and must be approved by the organizer.
Banners are made by the organizer.



Booking deadline: Sep. 9, 2026

Price: RMB 40,000

6. SNIEC Venue Advertising

1. Integrated Package

2. Online Package

3. Great Value Package

4. Digital Promotion

5. On-site Promotion

6. SNIEC Venue Advertising

7. Ad. around the SNIEC

6.7 LED Screen Ad. in Entrance Halls

During the Show

★★★
Recommendation

- o The exclusive multimedia display for playing your advertising video and bauma CHINA video on a loop

- o Location: As appropriate
- o Quantity: 1 piece

* Video is provided by the sponsor and must be approved by the organizer.
LED screen is provided by the organizer.

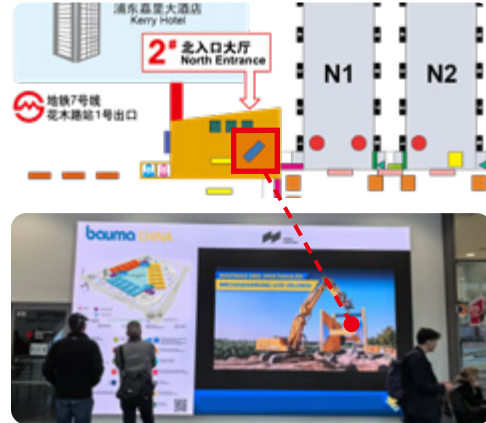

Booking deadline: Sep. 9, 2026

Price: RMB 150,000



6.8 Glass Facade Outside the Entrance Hall

During the Show

★★★
Recommendation

- o Ad. located in the golden triangle, connecting the outdoor area and the entrance hall

- o **Location 1:** Hall E1 to #1 South Entrance Hall (near Hall E1)
- o Size: 11.36m (W) × 3.36m (H)

- o **Location 2:** Hall E1 to #1 South Entrance Hall (near #1 South Entrance)

- o Size: 8.8m (W) × 3.36m (H)

- o **Location 3:** Hall W1 to #1 South Entrance Hall

- o Size: 32.9m (W) × 3.3m (H)

- o **Location 4:** Hall N1 to #2 North Entrance Hall (near Hall N1)

- o Size: 8.36m (W) × 3.51m (H)

- o **Location 5:** Hall W5 to #2 North Entrance Hall (near #2 North Entrance)

- o Size: 10.95m (W) × 3.61m (H)

- o **Location 6:** Hall E7 to #3 East Entrance Hall

- o Size: 34.27m (W) × 3.6m (H)

- o Quantity: 1 piece



* Ad. design is provided by the sponsor and must be approved by the organizer.
Banners are made by the organizer.

Booking deadline: Sep. 9, 2026

Price: RMB 80,000, Location 1 / Location 5
RMB 60,000, Location 2 / Location 4
RMB 180,000, Location 3
RMB 158,000, Location 6

6. SNIEC Venue Advertising

NEW 6.9 Connecting Galleria Glass Facade

During the Show

★★★
Recommendation

- Highly conspicuous outdoor placements capture attention of traversing visitors.
- **Location 1:** Inner circle corridor: Hall W4 to W5 / Hall E1 to E7 / Hall N1 to N5 (except N2 to N3)
- Size: 28.4m (W) × 5m (H)
- **Location 2:** Inner circle: Hall W1 to W4 / Hall E1 to E7 / Hall N1 to N5
- Size 1: 45m (W) × 7.2m (H)
- Size 2: 22.5m (W) × 7.2m (H)
- Quantity: 1 piece
- * Ad. design is provided by the sponsor and must be approved by the organizer.

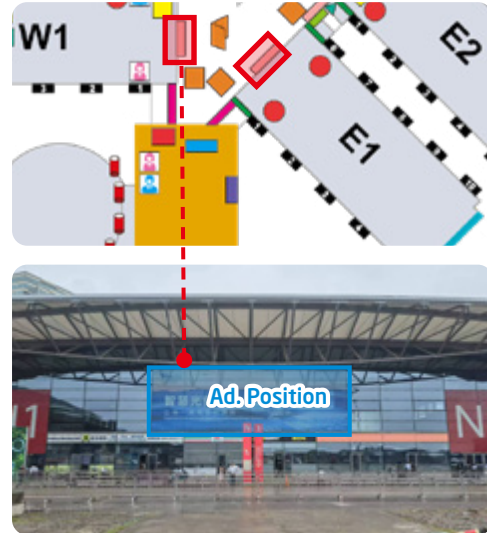

Booking deadline: Sep. 9, 2026

Price: RMB 200,000, Location 1
RMB 500,000, Location 2/Size 1
RMB 260,000, Location 2/Size 2

6.10 Corridor Billboard

During the Show

★★
Recommendation

- Decision-point signage guiding visitors near hall entries.
- **Location 1:** From Entrance to Halls
- **Location 2:** Hall W1 to W5 / Hall E1 to E7 / Hall N1 to N5 (except N2 to N3)
- Size: 6m (W) × 3m (H)
- Quantity: 1 piece
- * Ad. design is provided by the sponsor and must be approved by the organizer.
Billboards are made by the organizer.



Booking deadline: Sep. 9, 2026

Price: RMB 30,000, Location1
RMB 25,000, Location2

1. Integrated Package

2. Online Package

3. Great Value Package

4. Digital Promotion

5. On-site Promotion

6. SNIEC Venue Advertising

7. Ad. around the SNIEC

6. SNIEC Venue Advertising

1. Integrated Package

2. Online Package

3. Great Value Package

4. Digital Promotion

5. On-site Promotion

6. SNIEC Venue Advertising

7. Ad. around the SNIEC

6.11 Corridor Post

During the Show



Recommendation

- o Multiple placements along the route to maximize visibility.
 - o Location: Hall W1 to W5 / Hall E1 to E7 / Hall N1 to N5 (except N2 to N3)
 - o Size: 1m (W) × 2.5m (H)
 - o Quantity: 1 piece (MOQ: 4 pieces)
- * Ad. design is provided by the sponsor and must be approved by the organizer. Posts are made by the organizer.



Booking deadline: Sep. 9, 2026

Price: RMB 5,000, 1 piece (MOQ: 4 pieces)

6.12 Visitor Registration Signage

During the Show



Recommendation

- o Your company logo displayed on the signage where visitors scan the QR code for registration
 - o High-visibility opportunity to reach every attendee at first contact
 - o Size: 1m (W) × 2.5m (H)
- * Ad. design is provided by the sponsor and must be approved by the organizer. Ads. are printed by the organizer.



Booking deadline: Sep. 9, 2026

Price: RMB 18,000

6. SNIEC Venue Advertising

6.13 Floor Marks

During the Show

★ Recommendation

- Directional floor graphics that guide visitors straight to your booth.
 - Location: Indoor max quantity: 8
Outdoor Floor Marks will be set to corridors of halls
 - Size: 1m (W) × 2m (H)
 - Quantity: 1 piece
- * Ad. design is provided by the sponsor and must be approved by the organizer
Ads. are printed by the organizer



Booking deadline: Sep. 9, 2026

Price: RMB 8,000

6.14 Rest Area

During the Show

★★ Recommendation

- Ad. on background at rest area is noticeable since visitors will stay long there.
 - Quantity: 1 piece
- * Specific location as appropriate.
Ad. design is provided by the sponsor and must be approved by the organizer.
Ads. are printed by the organizer.



Booking deadline: Sep. 9, 2026

Price: RMB 50,000

1. Integrated Package

2. Online Package

3. Great Value Package

4. Digital Promotion

5. On-site Promotion

6. SNIEC Venue Advertising

7. Ad. around the SNIEC

6. SNIIEC Venue Advertising

1. Integrated Package

2. Online Package

3. Great Value Package

4. Digital Promotion

5. On-site Promotion

6. SNIIEC Venue Advertising

7. Ad. around the SNIIEC

6.15 Toilets Ad.

During the Show



Recommendation

- o Guaranteed attention in a confined space—high visibility.
 - o **Location 1:** #1 South Entrance / #2 North Entrance Hall
 - o **Location 2:** Hall W1-W5
 - o Size: 0.4m (W) × 0.6m (H)
 - o Quantity: 1 room
- * Ad. design is provided by the sponsor and must be approved by the organizer.
Ads. are printed by the organizer.



Booking deadline: Sep. 9, 2026

Price: RMB 50,000, Location 1
RMB 38,000, Location 2

6.16 Hall Floorplan Guide

During the Show



Recommendation

- o Logo or QR code on the floorplan in each exhibition hall—help visitors find you easily.
 - o Location: Eye-catching location of each exhibition hall
 - o Quantity: 2 pieces/set
- * QR code or Logo is provided by the sponsor and must be approved by the organizer.
Ads. are printed by the organizer.



Booking deadline: Sep. 9, 2026

Price: RMB 10,000

6. SNIIEC Venue Advertising

NEW 6.17 Self-service Badge Printer

During the Show

★★★
Recommendation

- Every visitor must pass through the entrance gate.
 - An unmissable branding opportunity.
 - Location : Hall W1 / Hall W5 / #3 East Entrance Hall
 - Size: 1.08m (W) × 1.92m (H)
- * Ad. design is provided by the sponsor and must be approved by the organizer.
Ads. are printed by the organizer.



Booking deadline: Sep. 9, 2026

Price: RMB 200,000

1. Integrated Package

2. Online Package

3. Great Value Package

4. Digital Promotion

5. On-site Promotion

6. SNIIEC Venue Advertising

7. Ad. around the SNIIEC

7. Ad. around the SNIEC

Excl. 7.1 Outside Corridor Ad. at the North Square

- The most attractive Ad. at the North Square and it is located between North Entrance Hall and Kerry Hotel.
- **Location 1:** North Square to Kerry Hotel
- Size: 18.84m (W) × 13m (H)
- **Location 2:** North Square
- Size: 28m (W) × 8m (H)
- Quantity: 1 piece
- * Ad. design is provided by the sponsor and must be approved by the organizer.
Ads. are printed by the organizer.

During the Show

★★★
Recommendation

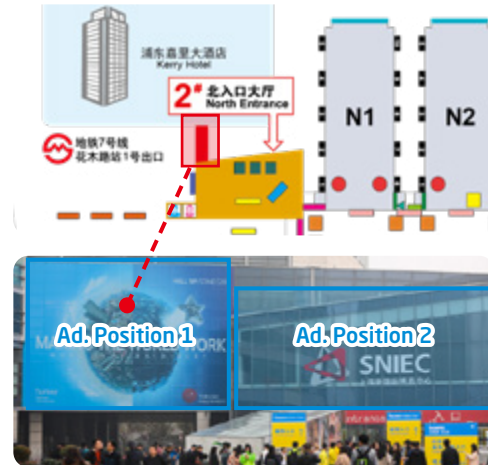

Booking deadline: Sep. 9, 2026

Price: RMB 500,000

7.2 Entrance Square Billboard

- Ad. on outdoor billboard next to entrance hall —impossible to miss.
- **Location 1:** South Square
- **Location 2:** North Square
- **Location 3:** East Square
- Size: 8m (W) × 5m (H)
- Quantity: 1 piece
- * Ad. design is provided by the sponsor and must be approved by the organizer.
Ads. are printed by the organizer.

During the Show

★★★
Recommendation



Booking deadline: Sep. 9, 2026

Price: RMB 60,000, South Square
RMB 60,000, North Square
RMB 35,000, East Square

1. Integrated Package

2. Online Package

3. Great Value Package

4. Digital Promotion

5. On-site Promotion

6. SNIEC Venue Advertising

7. Ad. around the SNIEC

7. Ad. around the SNIIEC

Excl. 7.3 Outside Wall Sticker Ad. at the North Square

- o Huge Ad. of the North Square near the subway — mass exposure to foot traffic.
- o Location: North Square
- o Size: 7.5m (W) × 14m (H)
- o Quantity: 1 piece
- * Ad. design is provided by the sponsor and must be approved by the organizer. Ads. are printed by the organizer.
- * The wall Ad. is made of special materials, which may cause some flaws in the picture

During the Show ★★★★ Recommendation



Booking deadline: Sep. 9, 2026

Price: RMB 250,000

7.4 Perforated Window Ad. (Hall Exterior)

- o Massive window ad—striking from long distance.
- o **Location 1:** Out of Hall W5
- o Size: 52.5m (W) × 13.2m (H)
- o **Location 2:** Out of Hall W1-W4/Hall E1-E7/Hall N1-N5
- o Size: 52.5m (W) × 7.2m (H)
- o Quantity: 1 piece
- * Ad. design is provided by the sponsor and must be approved by the organizer. Ads. are printed by the organizer.

During the Show ★★★ Recommendation

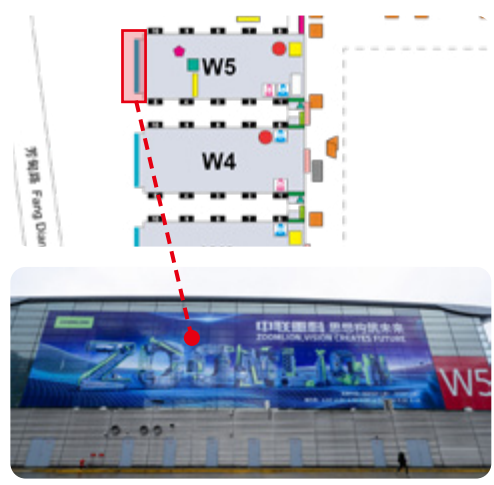

Booking deadline: Sep. 9, 2026

Price: RMB 500,000, Location 1
RMB 350,000, Location 2

1. Integrated Package

2. Online Package

3. Great Value Package

4. Digital Promotion

5. On-site Promotion

6. SNIIEC Venue Advertising

7. Ad. around the SNIIEC

7. Ad. around the SNIIEC

NEW 7.5 Ad. in VIP Parking Lot

During the Show



Recommendation

- o Ad. in the only VIP parking lot in SNIIEC to targets top-tier attendees.
- o Location: South Square
- o **Size 1:** 12m (W) × 7.2m (H)
- o **Size 2:** 36m (W) × 7.2m (H)
- o Quantity: 1 piece
- * Ad. design is provided by the sponsor and must be approved by the organizer. Ads. are printed by the organizer.
- * Some parts of the Ad. in Size 2 may be blocked by the columns



Booking deadline: Sep. 9, 2026

Price: RMB 100,000, Size 1
RMB 250,000, Size 2

7.6 Ad. in Front of the Gate at the South Square

During the Show



Recommendation

- o Key entry point Ad. to capture attention from all major visitor flows.
- o Location: South Square
- o Size: 2m (W) × 2.5m (H)
- o Quantity: 1 piece/4 sides
6 pieces/4 sides
- * Ad. design is provided by the sponsor and must be approved by the organizer. Ads. are printed by the organizer

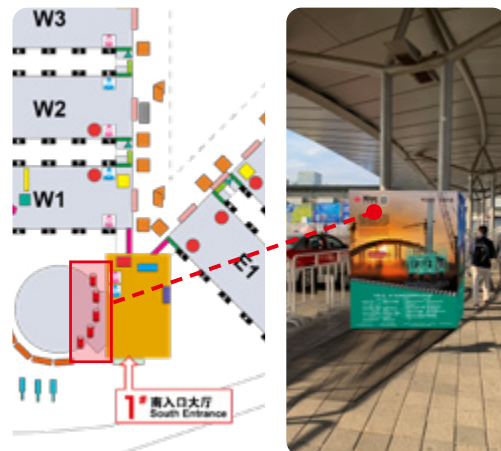

Booking deadline: Sep. 9, 2026

Price: RMB 35,000, 1 piece/4 sides
RMB 180,000, 6 pieces/4 sides

1. Integrated Package

2. Online Package

3. Great Value Package

4. Digital Promotion

5. On-site Promotion

6. SNIIEC Venue Advertising

7. Ad. around the SNIIEC

8. Location Map of On-site Ad.

1#

South Entrance

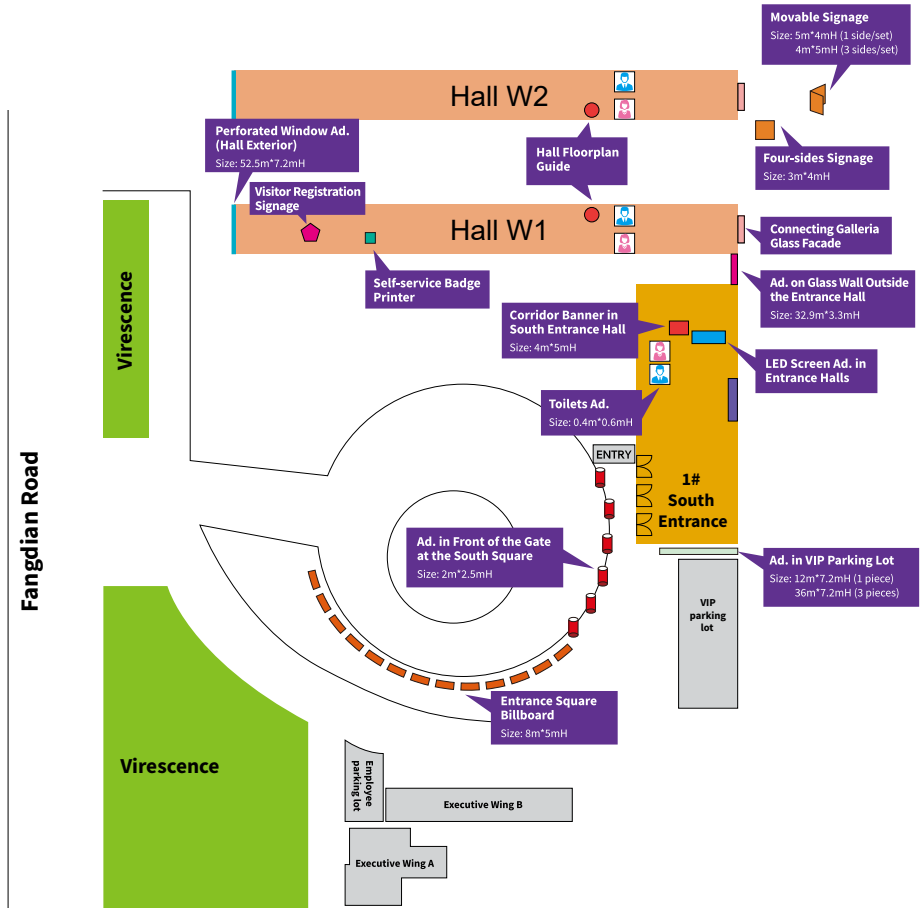
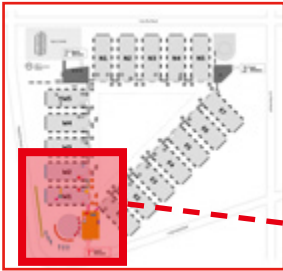

2#

North Entrance

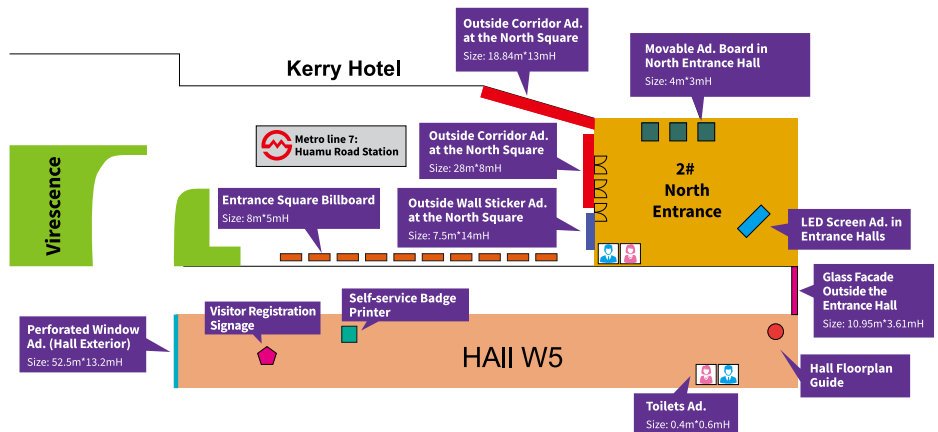

8. Location Map of On-site Ad.

3#

East Entrance

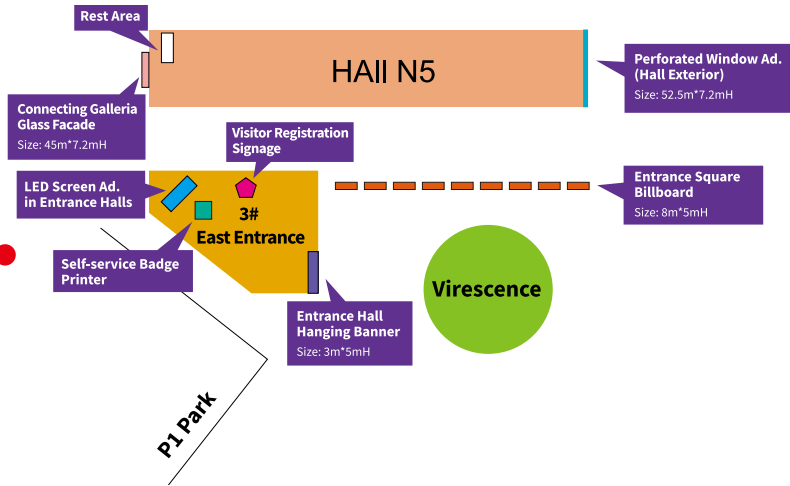

On-site AD

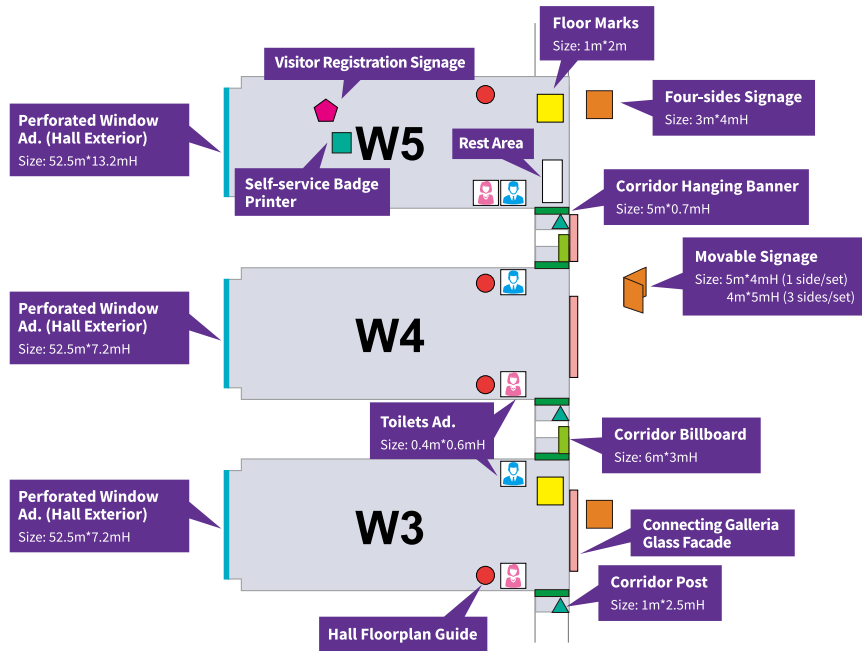

8. Location Map of On-site Ad.



- | | | | | | |
|--|--|--|-----------------------------------|--|--|
| | 6.1 Movable Signage | | 6.11 Corridor Post | | 7.1 Outside Corridor Ad. at the North Square |
| | 6.2 Four-sides Signage | | 6.12 Visitor Registration Signage | | 7.2 Entrance Square Billboard |
| | 6.3 Corridor Hanging Banner | | 6.13 Floor Marks | | 7.3 Outside Wall Sticker Ad. at the North Square |
| | 6.4 Entrance Hall Hanging Screen | | 6.14 Rest Area | | 7.4 Perforated Window Ad. (Hall Exterior) |
| | 6.5 Corridor Banner in South Entrance Hall | | 6.15 Toilets Ad. | | 7.5 Ad. in VIP Parking Lot |
| | 6.6 Movable Ad. Board in North Entrance Hall | | 6.16 Hall Floorplan Guide | | 7.6 Ad. in Front of the Gate at the South Square |
| | 6.7 LED Screen Ad. in Entrance Halls | | 6.17 Self-service Badge Printer | | |
| | 6.8 Glass Facade Outside the Entrance Hall | | | | |
| | 6.9 Connecting Galleria Glass Facade | | | | |
| | 6.10 Corridor Billboard | | | | |

Contact us

Messe München GmbH

Ms. Natalie Schröckmayr

11F, Tower 1, LJZ Financial Holdings Plaza, 1788-1800 Century Avenue, Pudong New Area, Shanghai (200122)

Tel.: (+49) 89-949-20252

E-mail: natalie.schroeckmayr@messe-muenchen.de